



1,2 - University of Adam Mickiewicz, Kalisz  
3,4 - GREEN CORNER - eco-friendly office building, Warsaw



# ALUFIRE

aluminium fire rated constructions

**ALUFIRE**<sup>®</sup>  
aluminium fire rated constructions

ALUFIRE Sp. z o.o. sp.k.  
87-148 Łysomice k/Torunia  
ul. Warszawska 64 A  
tel. + 48 56 674 88 30  
www.alufire.pl  
e-mail: biuro@alufire.pl

DOSTRIBUTOR / INSTALLER



87-148 Łysomice k/Torunia  
ul. Warszawska 64 A  
tel. + 48 56 674 88 11

**DOOR  
WINDOWS  
PARTITIONS**

**EI 15, EI 30, EI 60, EI 120**

**www.alufire.it**





ALUFIRE aluminium fire rated products are constructed to the highest quality standards and are among the finest in Europe. Because the safety and confidence of our customers is very important to us, all our fire rated doors, windows and partitions are rigorously tested to demonstrate compliance with the European Classifications EI 30, EI 60, and EI 120.

Due to the highly engineered and robust construction our systems have arguably the highest acoustic coefficient on the market:  $R_w = 41\text{dB}$  for internal constructions and  $R_w = 44\text{dB}$  for external constructions.

Dependencies between the width of the clear opening, the external dimension and the width of the opening in the wall - for single-leaf and double-leaf doors.

Single-leaf doors		
Width of clear door opening Spd [mm] Spd	External width of construction S [mm] Spd +220mm	Width of the opening in the wall So [mm] Spd + 250 mm
800	1020	1050
900	1120	1150
1000	1220	1250
1100	1320	1350
1200	1420	1450

Dependencies between the height of the clear opening, external dimension and the height of the opening in the wall for the single- and double-leaf doors

Doors without a threshold		
Height of clear door opening Hp [mm] Hp	External height of construction H [mm] Hp +70mm	Height of the opening in the wall Ho [mm] Hp + 90 mm
2000	2070	2090
2100	2170	2190
2200	2270	2290
2300	2370	2390
2400	2470	2490

Double-leaf door		
Width of clear door opening Spd [mm] Spd	External width of construction S [mm] Spd +300mm	Width of the opening in the wall So [mm] Spd + 330 mm
1200	1500	1530
1300	1600	1630
1400	1700	1730
1500	1800	1830
1600	1900	1930
1700	2000	2030
1800	2100	2130
1900	2200	2230
2000	2300	2330
2100	2400	2430
2200	2500	2530

Doors with a low threshold of 10 mm to be used inside		
Height of clear door opening Hp [mm] Hp	External height of construction H [mm] Hp +80mm	Height of the opening in the wall Ho [mm] Hp + 100 mm
2000	2080	2100
2100	2180	2200
2200	2280	2300
2300	2380	2400
2400	2480	2500

Doors with a high threshold of 20 mm to be used outside		
Height of clear door opening Hp [mm] Hp	External height of construction H [mm] Hp +90mm	Height of the opening in the wall Ho [mm] Hp + 110 mm
2000	2090	2110
2100	2190	2210
2200	2290	2310
2300	2390	2410
2400	2490	2510

### ALUFIRE Maximum door dimensions

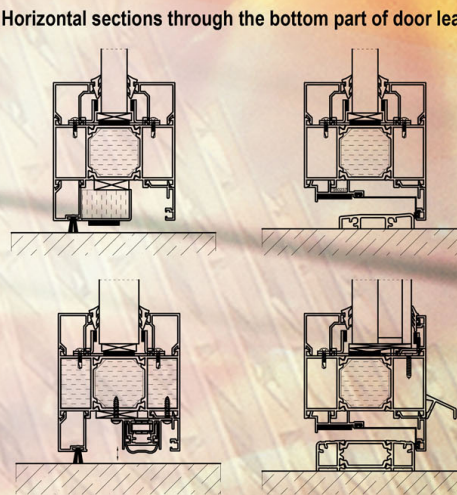
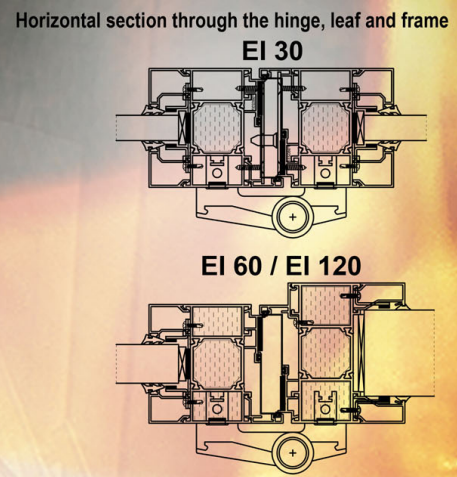
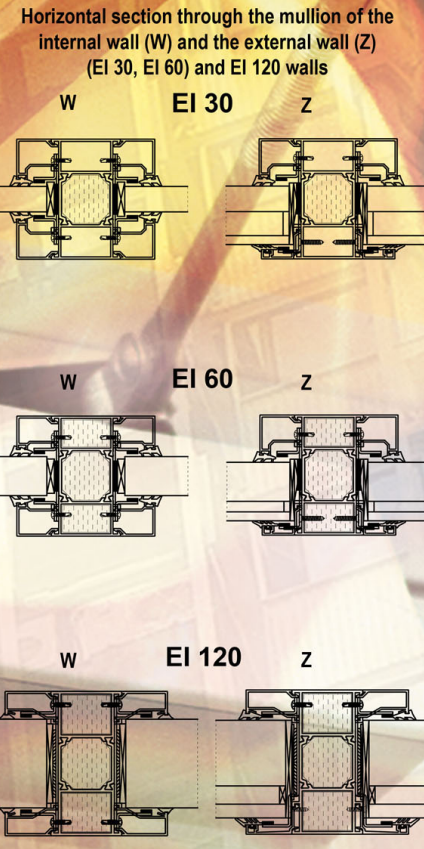
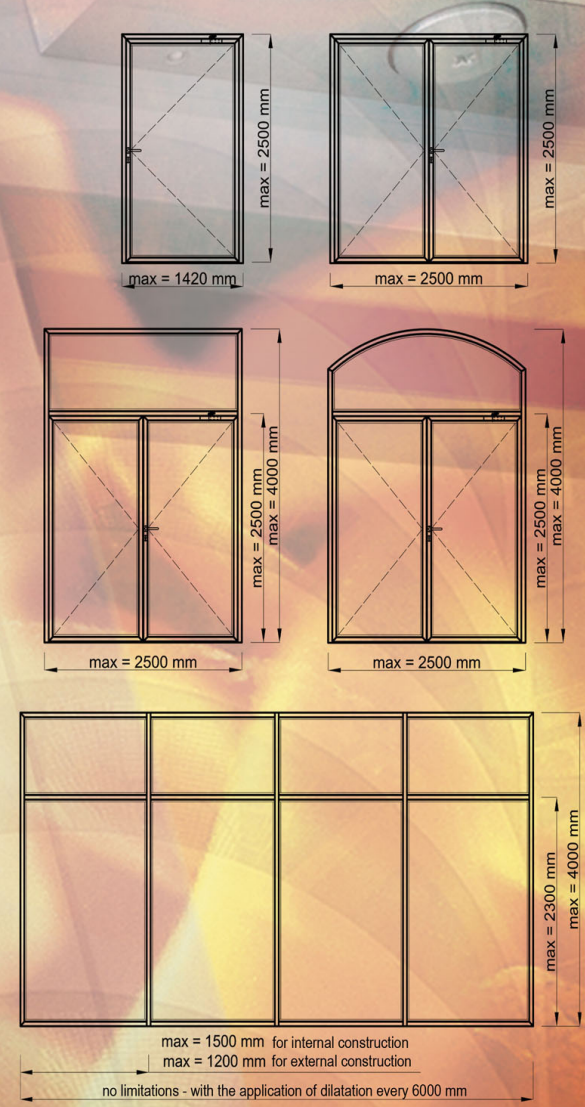

### HARDWARE AND ACCESSORIES OF FIRE-RATED DOORS

- Stainless Steel U-form type safe handle with divided oval rosette and a fixed door knob to control access on one side
- Arm self-closer
- Slip rail self-closer
- Hinge
- Drive
- Pusher for aerating door
- Electromagnetic door retainer
  - wall - mounted
  - floor - mounted
- Anti-panic hardware
- Ventilation grille 300x 150 mm
- Adjustor of closing sequence (RKZ) - integrated with slip rail self-closers - lever
- Access control:**
  - Single-sided/averse electric strike (single-sided access control)
  - Double-sided/reverse electric strike (double-sided access control)
  - Electromagnetic deadbolt (double-sided access control)
  - Electric lock (single- and duple-sided acces control)





ALUFIRE Vision Line - frameless fire resistant glazed screens

# ALUFIRE<sup>®</sup>

fire resistant glazing solutions



ALUFIRE Classic - aluminium framed fire resistant glazed screens





NHS, WOKINGHAM HOSPITAL, WINDSOR WING



NHS, THE PRINCESS ALEXANDRA HOSPITAL, HARLOW



NHS, THE PRINCESS ALEXANDRA HOSPITAL, HARLOW



NHS, WOKINGHAM HOSPITAL, ASCOT WING



NHS, ST. GEORGES HOSPITAL, LONDON



NHS, WOKINGHAM HOSPITAL, WINDSOR WING

[www.ALUFIRE<sup>®</sup>.it](http://www.ALUFIRE.it)



CHECKMATE OFFICE, DUNMOW



CHECKMATE OFFICE, DUNMOW